

アナログ

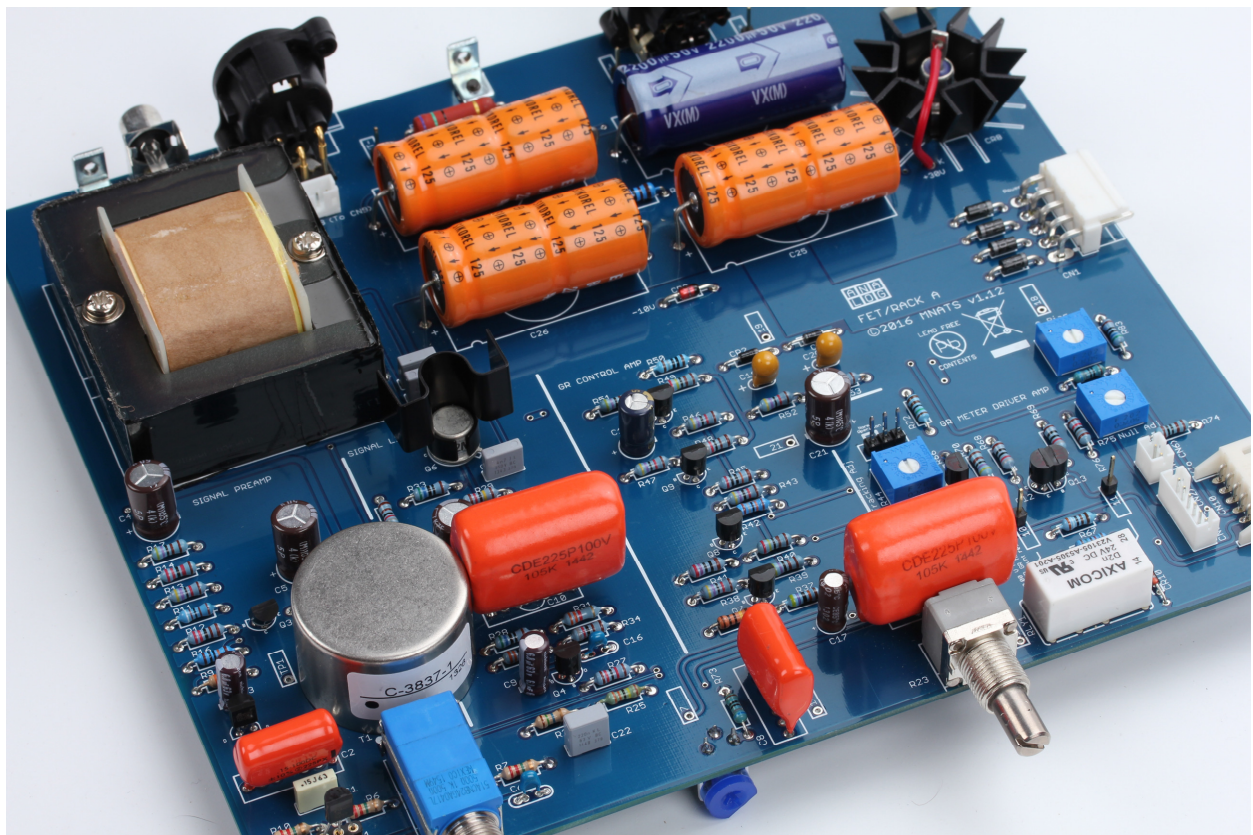

FET/RACK A Limiter  
Main PCB Overlay, Schematic and Bill of Materials

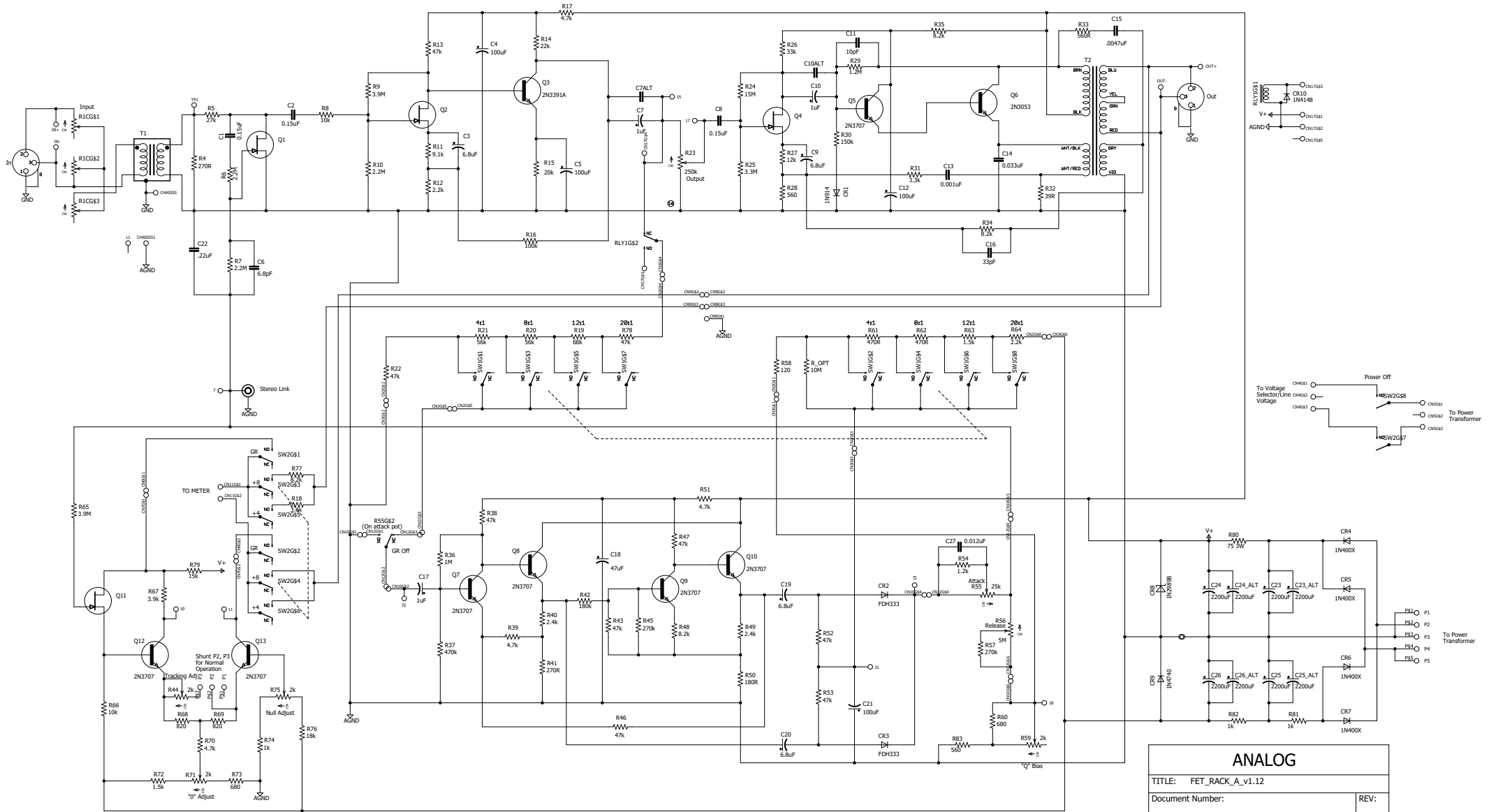



### ANALOG

TITLE: FET_RACK_A_v1.12	
Document Number:	REV:
Date: 26/04/2016 7:13 AM	Sheet: 1/1

FET/RACK Rev A Bill of Materials

Quantity	Part	Value	Part Number	Description	Package	Notes
1	C1	0.15uF		Capacitor, Film	CAP_FILM_5X7.2	
2	C2, C8	0.15uF		Capacitor, Film	CAP_FILM_6X17.5_VAR_PITCH	
2	C3, C9	6.8uF		Radial Electrolytic Capacitor	RAD4/1.5	
4	C4, C5, C12, C21	100uF		Radial Electrolytic Capacitor	RAD8/3.5	
1	C6	6.8pF		Capacitor, Ceramic	CAP1-2	
3	C7, C10, C17	1uF		Radial Electrolytic Capacitor	RAD5/2	
2	C7ALT, C10ALT	1uF		Capacitor, Film	CAP_FILM_6X17.5_VAR_PITCH	
1	C11	10pF		Capacitor, Ceramic	CAP1-2	
1	C13	0.001uF		Capacitor, Ceramic	CAP1-2	
1	C14	0.033uF		Capacitor, Film	CAP2_RECT	
1	C15	.0047uF		Capacitor, Film	CAP2_RECT	
1	C16	33pF		Capacitor, Ceramic	CAP1-2	
1	C18	47uF		Radial Electrolytic Capacitor	RAD6.3/2.5	
2	C19, C20	6.8uF		Capacitor, Tantalum	CAP1_POL	
1	C22	.22uF		Capacitor, Film	CAP2_RECT	
1	C23_ALT	2200uF/50V		Radial Electrolytic Capacitor		
3	C24_ALT, C25_ALT, C26_ALT	2200uF		Radial Electrolytic Capacitor	RAD16/7.5	
1	C23	2200uF/50V		Axial Electrolytic Capacitor		
3	C24, C25, C26	2200uF		Axial Electrolytic Capacitor	CAP_AXIAL_18X41	
1	C27	0.012uF		Capacitor, Film	CAP2_RECT	Attack/Release PCB
2	CR1, CR10		1N914	Diode	DO-35-0.4	
2	CR2, CR3		FDH333	Diode, Low Leakage	DO-35-0.4	
4	CR4, CR5, CR6, CR7		1N4004	Diode	DO-41	
1	CR8		1N2989B	Zener Stud Diode	DO4	
1	CR9		1N4740	Zener Diode	DO-35-0.4	
2	Q1, Q11		2N5457	FET N-CHANNEL	TO-92_INLINE	
2	Q2, Q4		J309	FET N-CHANNEL	TO-92	
1	Q3		2N3391A	Transistor, NPN	TO-92	
7	Q5, Q7, Q8, Q9, Q10, Q12, Q13		2N3707	Transistor, NPN	TO-92	
1	Q6		2N3053	Transistor, NPN	TO-39	
1	R_OPT	10M		1/4 Watt Resistor	MF1/4	Ratio PCB
2	R4, R41	270R		1/4 Watt Resistor	MF1/4	
1	R5	27k		1/4 Watt Resistor	MF1/4	
3	R6, R7, R10	2.2M		1/4 Watt Resistor	MF1/4	
2	R8, R66	10k		1/4 Watt Resistor	MF1/4	
2	R9, R65	3.9M		1/4 Watt Resistor	MF1/4	
1	R11	9.1k		1/4 Watt Resistor	MF1/4	
2	R12, R64	2.2k		1/4 Watt Resistor	MF1/4	R64 Ratio PCB
9	R13, R22, R38, R43, R46, R47, R52, R53, R78	47k		1/4 Watt Resistor	MF1/4	R22, R78 Ratio PCB
1	R14	22k		1/4 Watt Resistor	MF1/4	
1	R15	20k		1/4 Watt Resistor	MF1/4	
1	R16	100k		1/4 Watt Resistor	MF1/4	
4	R17, R39, R51, R70	4.7k		1/4 Watt Resistor	MF1/4	
1	R18	3.6k		1/4 Watt Resistor	MF1/4	Meter PCB
1	R19	68k		1/4 Watt Resistor	MF1/4	Ratio PCB
2	R20, R21	56k		1/4 Watt Resistor	MF1/4	Ratio PCB
1	R24	15M		1/4 Watt Resistor	MF1/4	
1	R25	3.3M		1/4 Watt Resistor	MF1/4	
1	R26	33k		1/4 Watt Resistor	MF1/4	
1	R27	12k		1/4 Watt Resistor	MF1/4	
1	R28	560		1/4 Watt Resistor	MF1/4	
1	R29	1.2M		1/4 Watt Resistor	MF1/4	
1	R30	150k		1/4 Watt Resistor	MF1/4	
1	R31	3.3k		1/4 Watt Resistor	MF1/4	
1	R32	39R		1/4 Watt Resistor	MF1/4	
1	R33	560R		1/4 Watt Resistor	MF1/4	
4	R34, R35, R48, R77	8.2k		1/4 Watt Resistor	MF1/4	R77 Meter PCB
1	R36	1M		1/4 Watt Resistor	MF1/4	
1	R37	470k		1/4 Watt Resistor	MF1/4	
2	R40, R49	2.4k		1/4 Watt Resistor	MF1/4	
1	R42	180k		1/4 Watt Resistor	MF1/4	
1	R45	200k		1/4 Watt Resistor	MF1/4	
1	R50	180R		1/4 Watt Resistor	MF1/4	
1	R54	1.2k		1/4 Watt Resistor	MF1/4	Attack/Release PCB
1	R57	270k		1/4 Watt Resistor	MF1/4	Attack/Release PCB
1	R58	120		1/4 Watt Resistor	MF1/4	Ratio PCB
2	R60, R73	680		1/4 Watt Resistor	MF1/4	
2	R61, R62	470R		1/4 Watt Resistor	MF1/4	Ratio PCB
2	R63, R72	1.5k		1/4 Watt Resistor	MF1/4	R63 Ratio PCB
1	R67	3.9k		1/4 Watt Resistor	MF1/4	
2	R68, R69	820		1/4 Watt Resistor	MF1/4	
1	R74	1k		1/4 Watt Resistor	MF1/4	
1	R76	18k		1/4 Watt Resistor	MF1/4	
1	R79	15k		1/4 Watt Resistor	MF1/4	
1	R80	75 3W	ERG-3SJ750	Resistor, 3 Watt	MF-3W	
2	R81, R82	1k		Resistor, 1/2 Watt	MF1/2	
1	R83	560		1/4 Watt Resistor	MF1/4	
1	R1C	600		T Pad	BOURNS_MODEL_51	
1	R23	250k		Potentiometer, Log Taper	P260_1/4"	

1	R55	25k	Potentiometer w/Switch	P260S-D1	Attack/Release PCB
1	R56	5M	Potentiometer	P260_1/4"	Attack/Release PCB
3	R44, R59, R75	2k	Trimmer Potentiometer	3386_TOP	
1	R71	2k	Trimmer Potentiometer	3306	
1	RCA1	161-0390-E	RCA Snap-Fit	RCA-900	
1	RLY1	V23105A5305A201	Relay	V23105A5305A201	
1	SW1	PBN-4	Push Button Switch Bank	PBN-4	Ratio PCB
1	SW2	PBN-4-15T	Push Button Switch Bank	PBN-4-15T	Meter PCB
1	T1	C-3837-1	Input Transformer	INPUT_TRANSFORMER_1.13	
1	T2	EA-5002-500	Audio Output Transformer	EA-5002	
1	U\$1		Header	3PIN_1_HEADER	
1	J1	NC3FAH1	XLR Connector	NC3FAH1	
1	XLR1	NC3MAH	XLR Connector	NC3MAH	
1		578305B00000G	Heat Sink		For Q6
1		695-1B	Heat Sink		For CR8
1	CN1	B5PS-VH	Connector	B5PS-VH	
2	CN10, CN17	S6B-XH-A-1	Connector	S6B-XH-A-1	
1	CN11	B2B-XH-A	Connector	B2B-XH-A	Meter PCB
1	CN12	06JQ-BT	Connector	06JQ-BT	Attack/Release PCB
2	CN2, CN3	B6B-PH-K-S	Connector	B6B-PH-K-S	CN2 Ratio PCB
2	CN4, CN5	B3P-VH	Connector	B3P-VH	Meter PCB
2	CN6, CN7	B2B-PH-K-S	Connector	B2B-PH-K-S	CN6 Meter PCB
2	CN8, CN9	B3B-PH-K-S	Connector	B3B-PH-K-S	CN9 Meter PCB